



(19) **United States**

(12) **Patent Application Publication**
Talebzadeh et al.

(10) **Pub. No.: US 2019/0251909 A1**

(43) **Pub. Date: Aug. 15, 2019**

(54) **PIXEL MEASUREMENT THROUGH DATA LINE**

Publication Classification

(71) Applicant: **Ignis Innovation Inc.**, Waterloo (CA)

(72) Inventors: **Jafar Talebzadeh**, Waterloo (CA); **Ray Leerenfeld**, Palgrave (CA)

(51) **Int. Cl.**
G09G 3/3283 (2006.01)
G09G 3/00 (2006.01)
G09G 3/325 (2006.01)
H05B 33/08 (2006.01)

(21) Appl. No.: **16/028,073**

(52) **U.S. Cl.**
CPC *G09G 3/3283* (2013.01); *H05B 33/0896* (2013.01); *G09G 3/325* (2013.01); *G09G 3/006* (2013.01)

(22) Filed: **Jul. 5, 2018**

(57) **ABSTRACT**

A system and method for determining the current of a pixel circuit and an organic light emitting diode (OLED). The pixel circuit is connected to a source driver by a data line. The voltage (or current) supplied to the pixel circuit by the source driver. The current of the pixel and the OLED can be measured by a readout circuit. A value of a voltage from the measured current can be extracted and provided to a processor for further processing.

Related U.S. Application Data

(63) Continuation-in-part of application No. 15/968,134, filed on May 1, 2018.

(60) Provisional application No. 62/629,450, filed on Feb. 12, 2018, now abandoned.

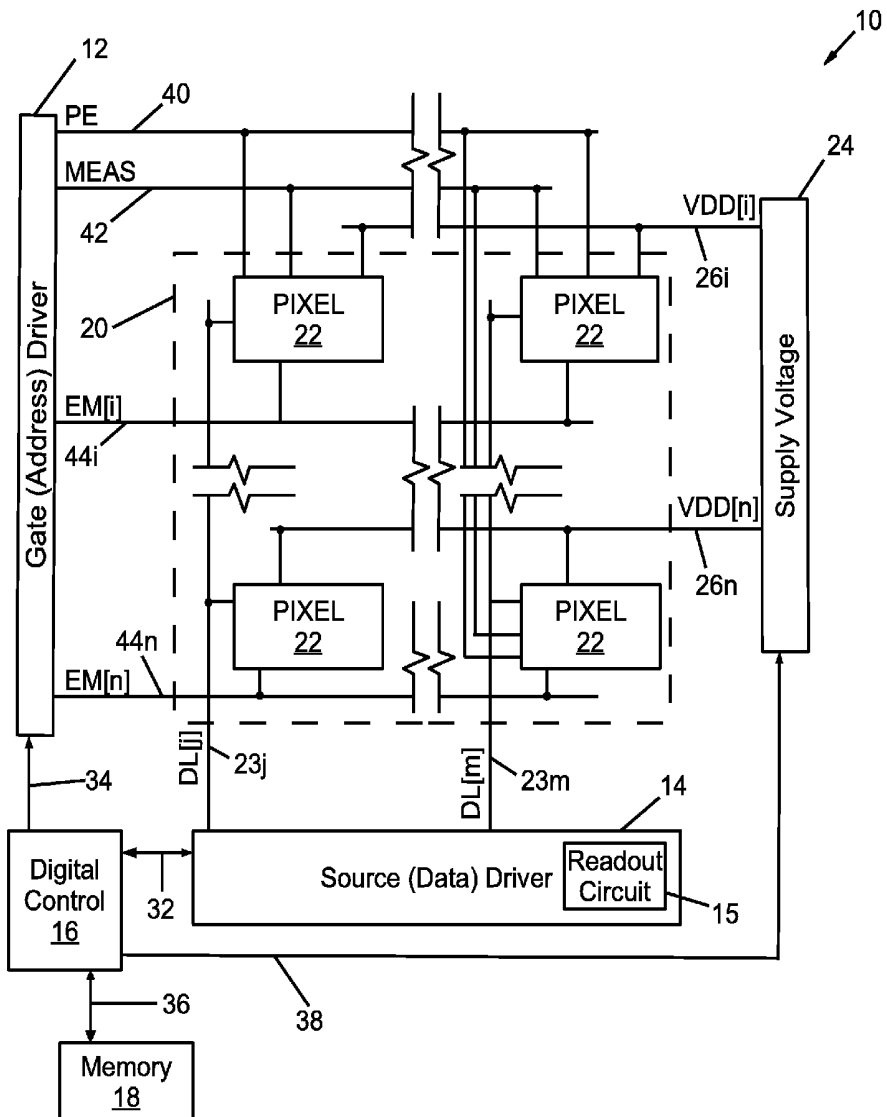

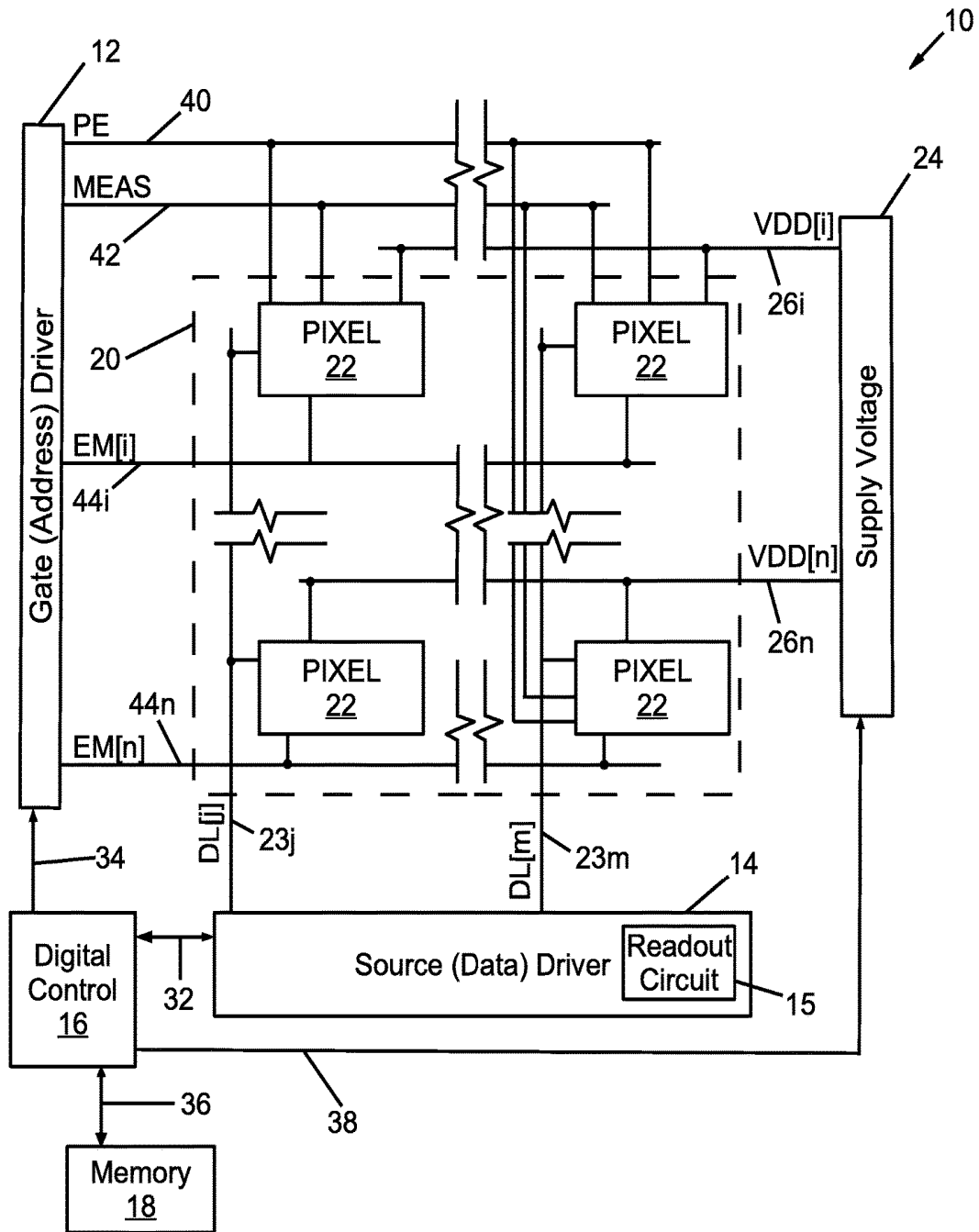

FIG. 1

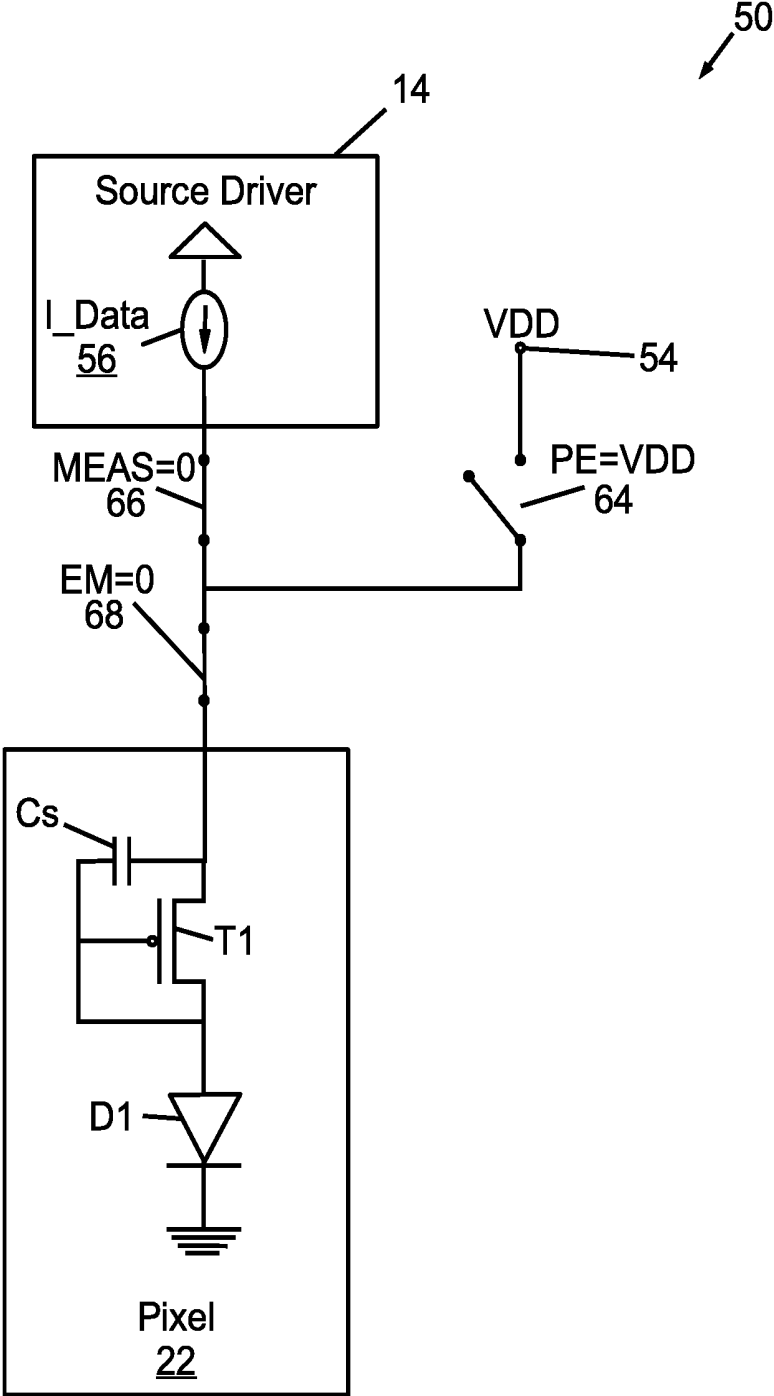

FIG. 2

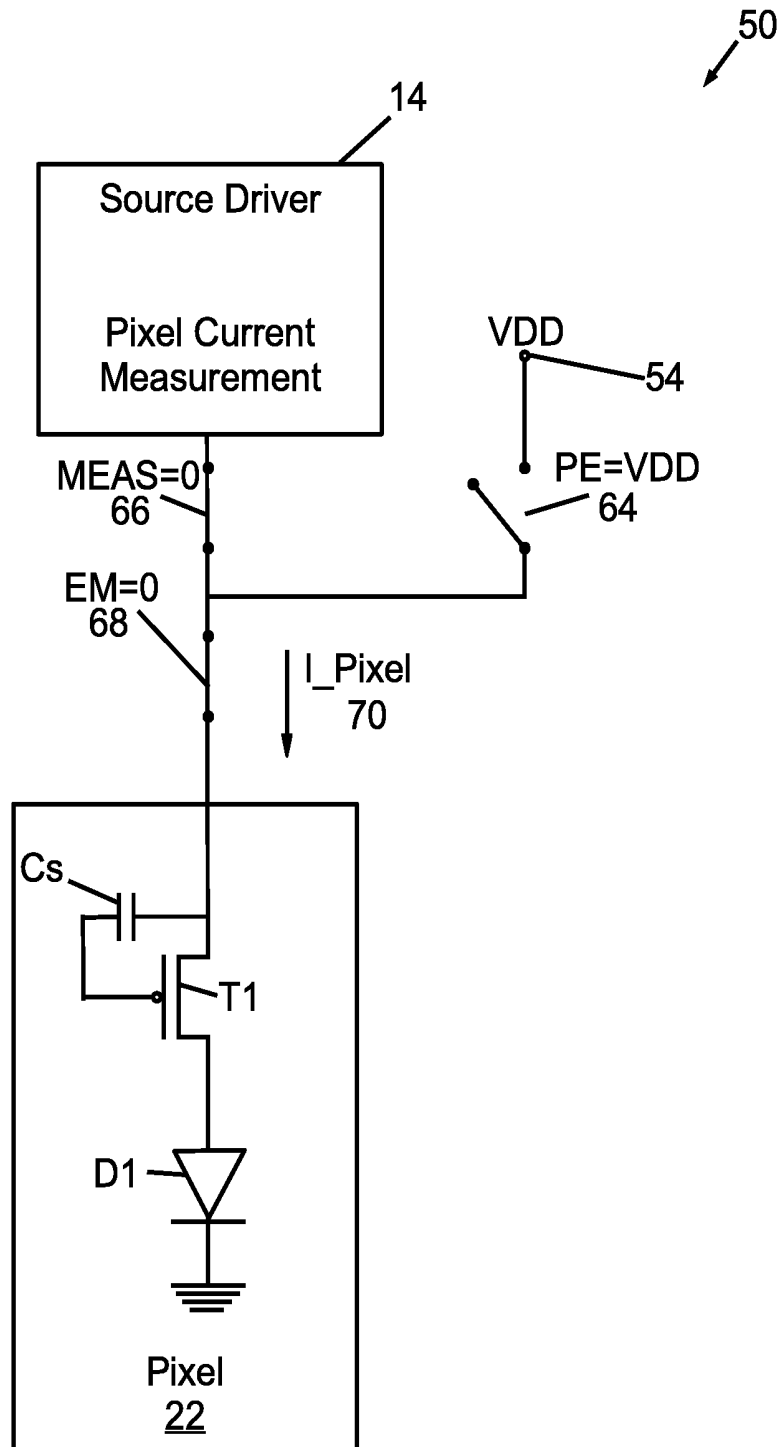

FIG. 3

50

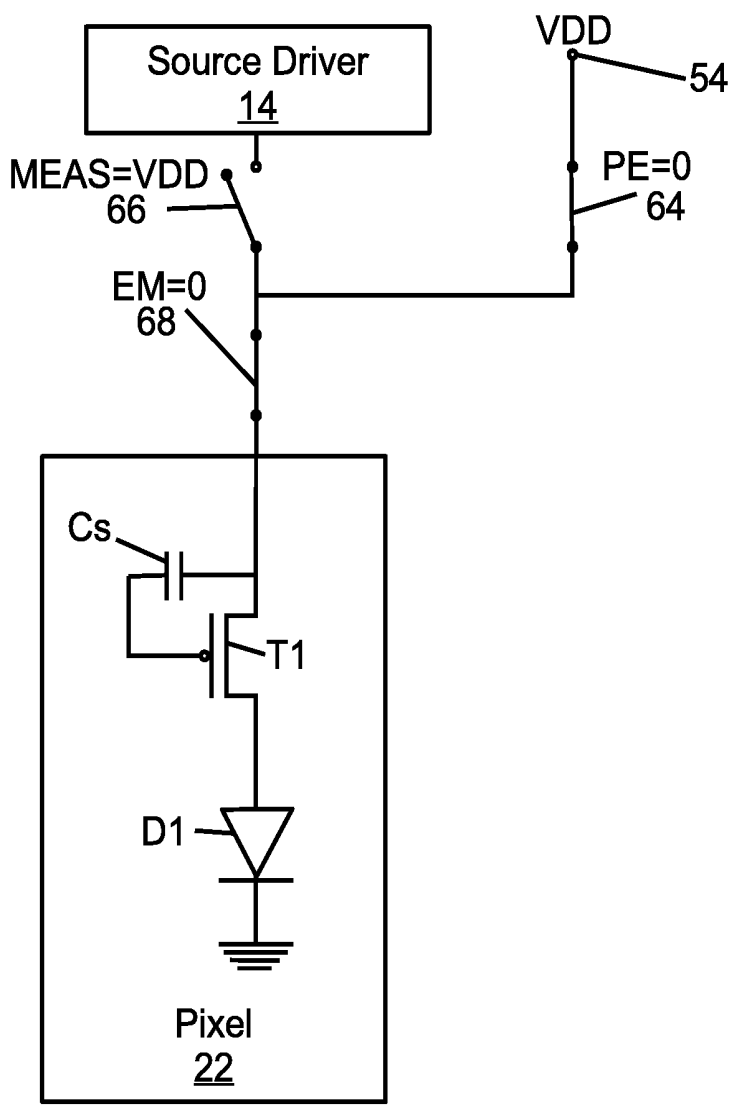

FIG. 4

50

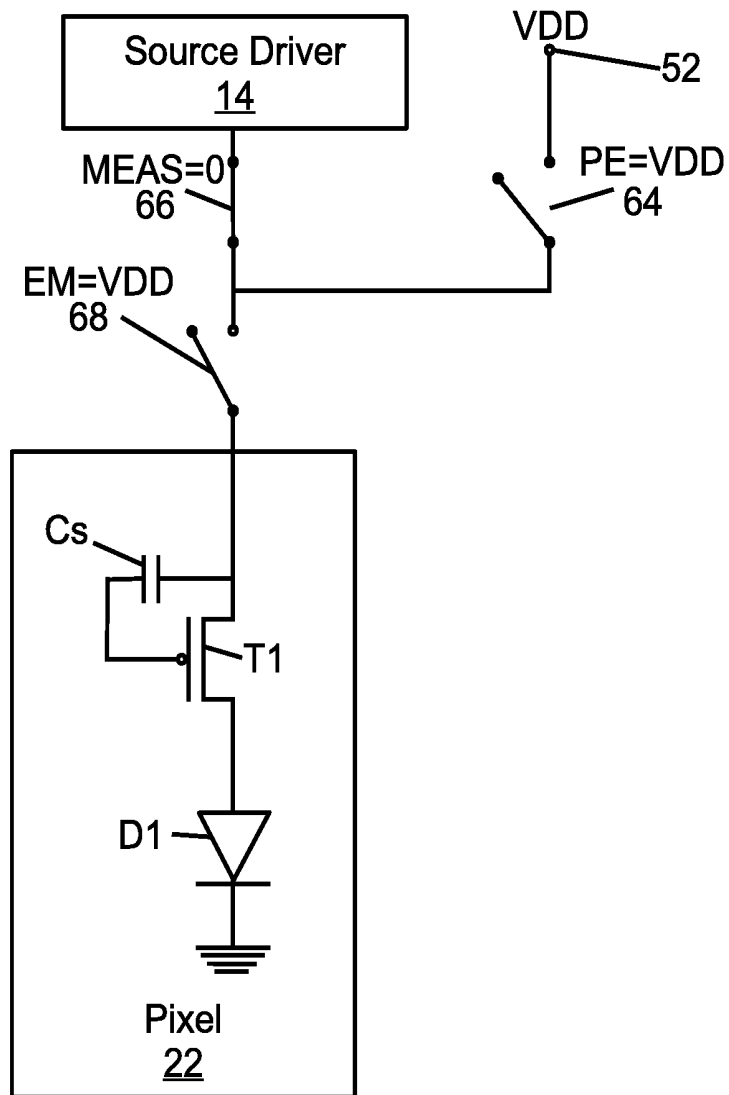

FIG. 5

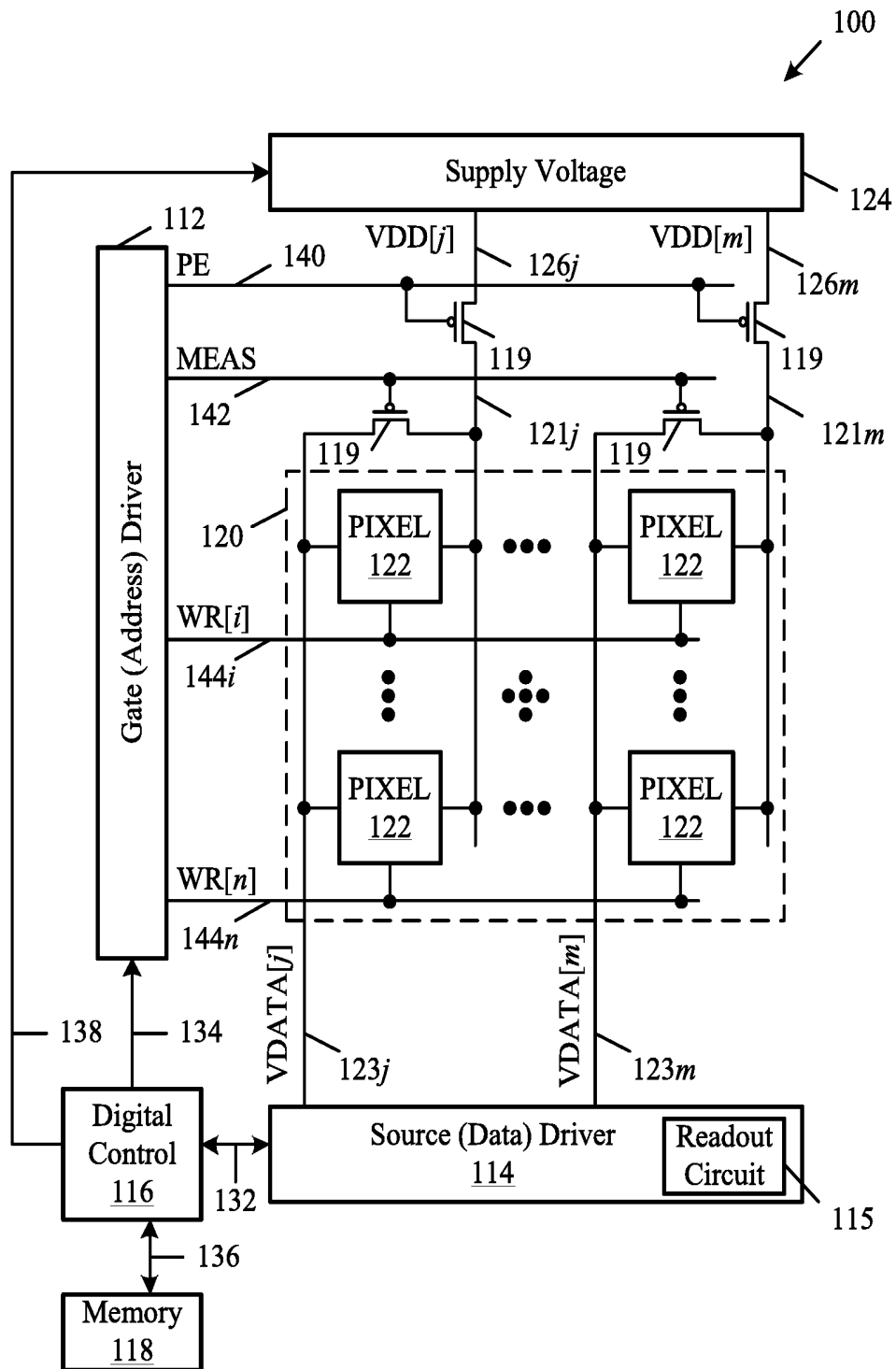

FIG. 6

200

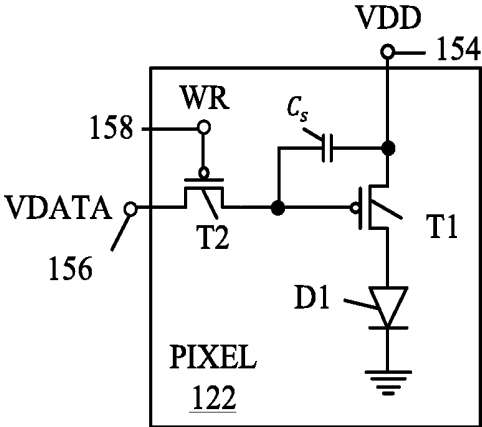

FIG. 7

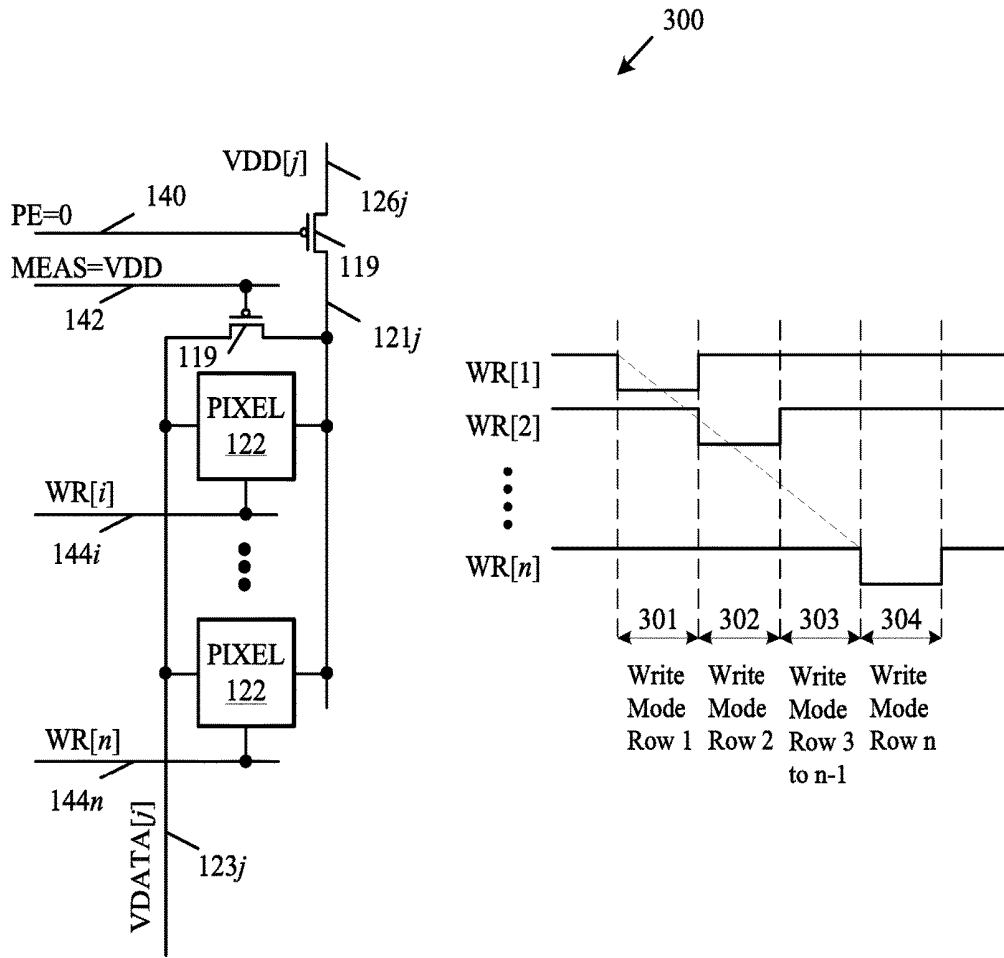

FIG. 8

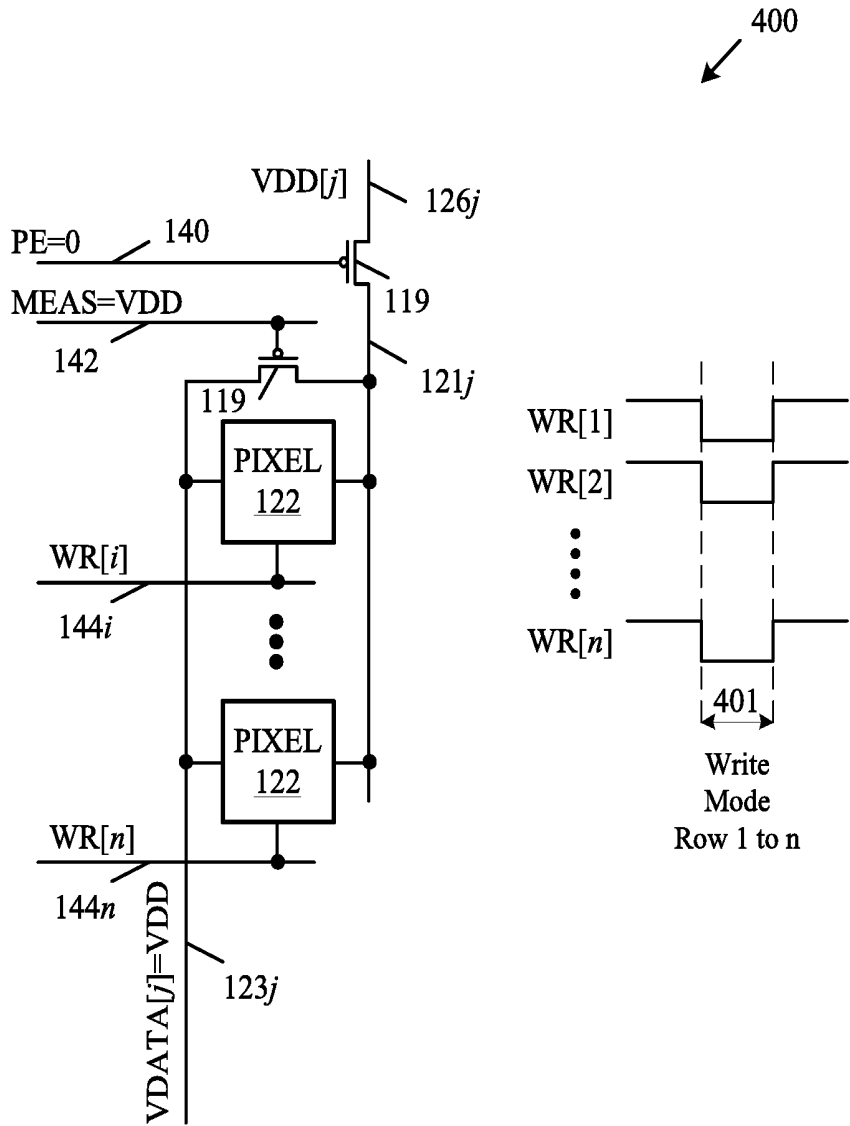

FIG. 9

500 ↙

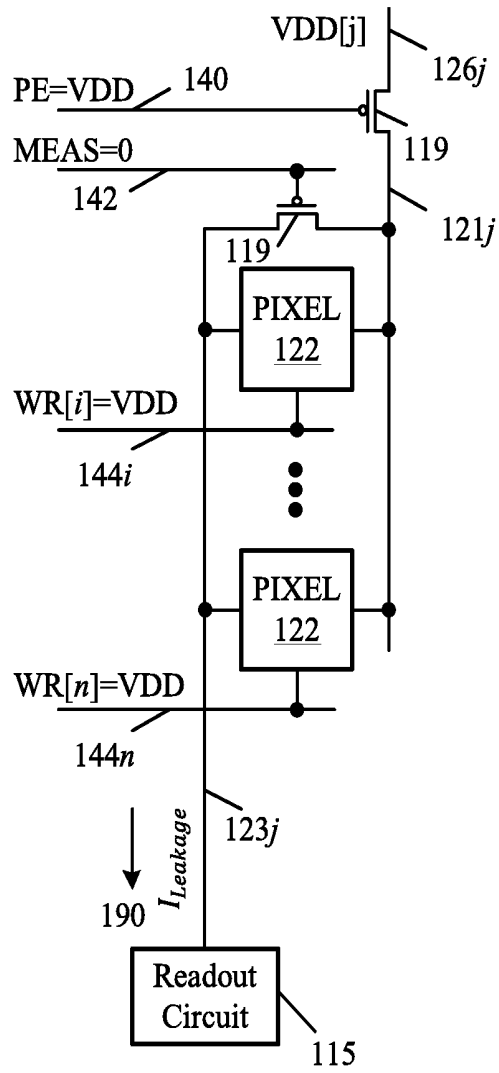

FIG. 10

600 ↙

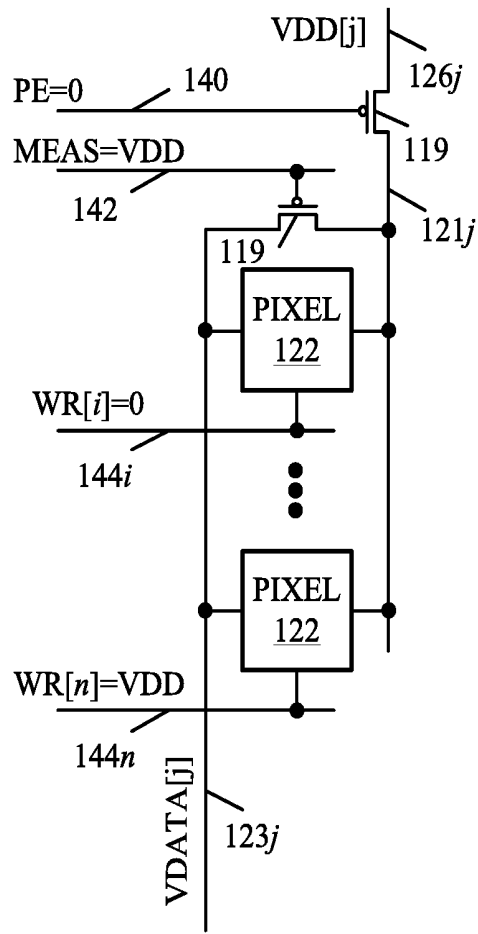

FIG. 11

700

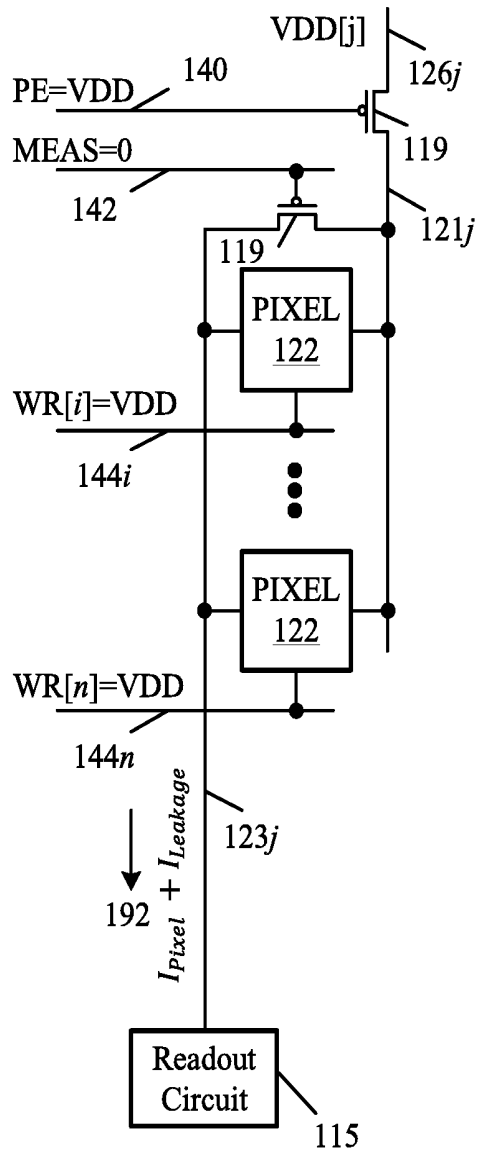

FIG. 12

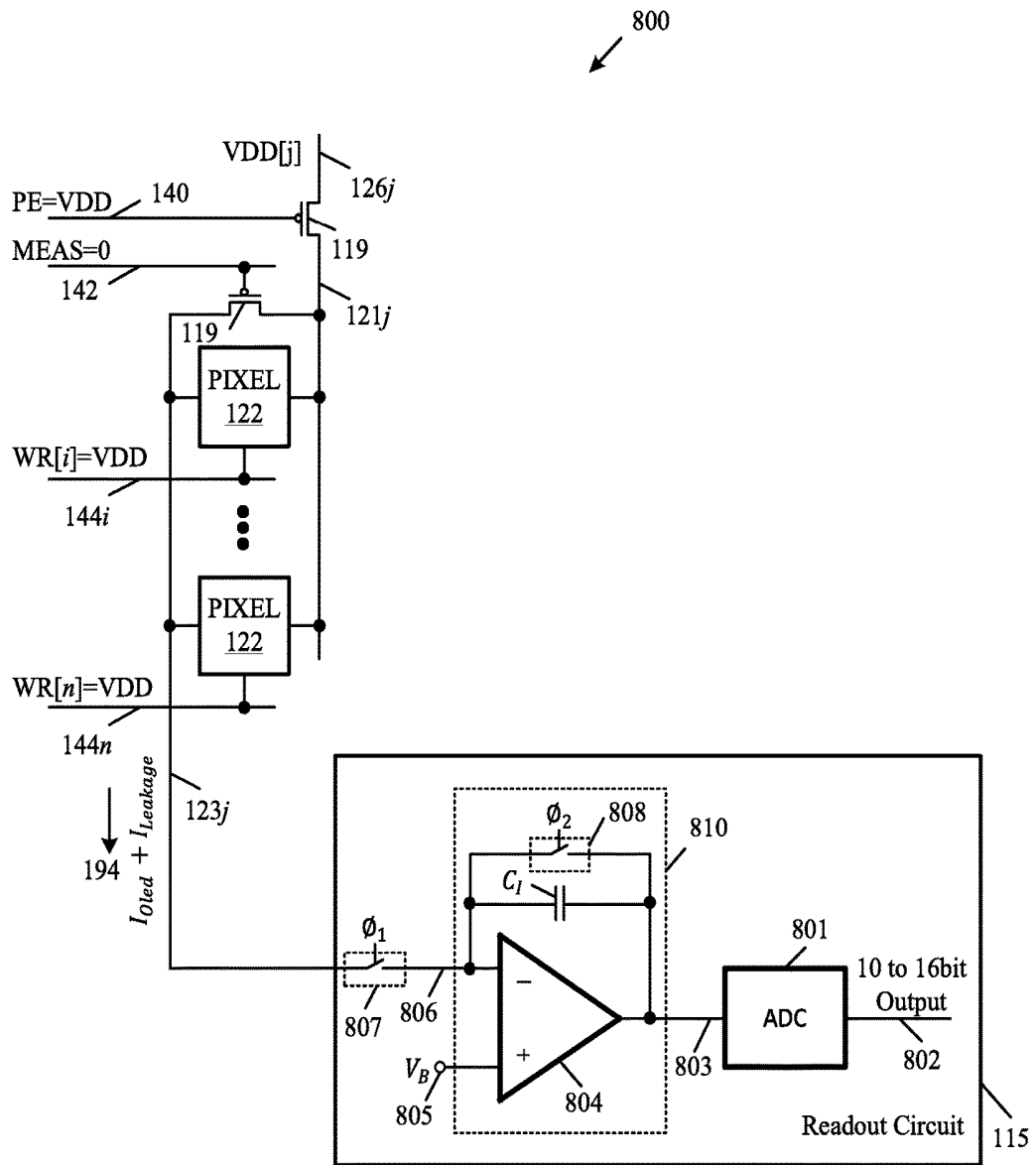

FIG. 13

PIXEL MEASUREMENT THROUGH DATA LINE

CROSS REFERENCE TO RELATED APPLICATIONS

[0001] This application is a continuation-in-part of U.S. patent application Ser. No. 15/968,134, filed May 1, 2018, which claims the benefit of U.S. Provisional Application No. 62/629,450, each of which is hereby incorporated by reference herein in their entireties.

BACKGROUND

[0002] Organic light emitting diode (OLED) displays have gained significant interest recently in display applications in view of their faster response times, larger viewing angles, higher contrast, lighter weight, lower power, amenability to flexible substrates, as compared to liquid crystal displays (LCDs).

[0003] OLED displays can be created from an array of light emitting devices each controlled by individual circuits (i.e., pixel circuits) having transistors for selectively controlling the circuits to be programmed with display information and to emit light according to the display information. Thin film transistors (“TFTs”) fabricated on a substrate can be incorporated into such displays. TFTs tend to demonstrate non-uniform behavior across display panels and over time as the displays age. Compensation techniques can be applied to such displays to achieve image uniformity across the displays and to account for degradation in the displays as the displays age. Some schemes for providing compensation to displays to account for variations across the display panel and over time utilize monitoring systems to measure time dependent parameters associated with the aging (i.e., degradation) of the pixel circuits. The measured information can then be used to inform subsequent programming of the pixel circuits so as to ensure that any measured degradation is accounted for by adjustments made to the programming. The prior art monitored pixel circuits, however, require the use of additional feedback lines and transistors to selectively couple the pixel circuits to the monitoring systems and provide for reading out information. The incorporation of additional feedback lines and transistors may undesirably add significantly to the cost yield and reduces the allowable pixel density on the panel.

SUMMARY OF THE INVENTION

[0004] Aspects of the present disclosure include a method of determining the current of a pixel circuit connected to a source driver by a data line. The method includes supplying voltage (or current) to the pixel circuit from the source via the data line, measuring the current and extracting the value of the voltage from the current measurement. The pixel circuit may include a light-emitting device, such as an organic light emitting diode (OLED), and may also include a thin field transistor (TFT).

[0005] In this aspect of the present disclosure further includes the source driver having a readout circuit that is utilized for measuring the current provided by the source driver to the pixel circuit. The current is converted into a digital code, i.e. a 10 to 16 bit digital code. The digital code is provided to a digital processor for further processing.

[0006] The foregoing and additional aspects and embodiments of the present invention will be apparent to those of

ordinary skill in the art in view of the detailed description of various embodiments and/or aspects, which is made with reference to the drawings, a brief description of which is provided next.

BRIEF DESCRIPTION OF THE DRAWINGS

[0007] FIG. 1 is a block diagram of an OLED display in accordance with embodiments of the present invention.

[0008] FIG. 2 is a block diagram of an embodiment of a pixel driver circuit in programming mode for the OLED display in FIG. 1.

[0009] FIG. 3 is a block diagram of an embodiment of a pixel driver circuit in measurement mode for the OLED display in FIG. 1.

[0010] FIG. 4 is a block diagram of an embodiment of a pixel driver circuit in normal operation mode for the OLED display in FIG. 1.

[0011] FIG. 5 is a block diagram of an embodiment of a pixel driver circuit in programming mode which is not selected by the Enable Management signal for the OLED display in FIG. 1.

[0012] FIG. 6 is a block diagram of an OLED display in accordance with embodiments of the present invention.

[0013] FIG. 7 is a block diagram of an embodiment of a pixel circuit which includes two TFTs, T1 and T2, an OLED and a capacitor.

[0014] FIG. 8 is a block diagram of an embodiment of a column of pixel circuit (“jth” column) in programming mode.

[0015] FIG. 9 is a block diagram of an embodiment of a column of pixel circuit (“jth” column). In this mode, data line has the same voltage as supply voltage (VDD) and all capacitors’ voltages are set to be zero and OLED devices show black color.

[0016] FIG. 10 is a block diagram of an embodiment of a column of pixel circuit (“jth” column) in measurement mode. The leakage current is measured in this mode.

[0017] FIG. 11 is a block diagram of an embodiment of a column of pixel circuit (“jth” column) in programming mode. In this mode the “ith” row is programmed.

[0018] FIG. 12 is a block diagram of an embodiment of a column of pixel circuit (“jth” column) in measurement mode. The pixel current of the “ith” pixel plus the leakage currents of the other pixels are measured in this mode.

[0019] FIG. 13 is a block diagram of an embodiment of a column of pixel circuit (“jth” column) in measurement mode. The OLED current of the “ith” pixel plus the leakage currents of the other pixels are measured in this mode.

DETAILED DESCRIPTION

[0020] FIG. 1 is a diagram of an exemplary display system 10. The display system 10 includes a gate driver 12, a source driver 14, a digital controller 16, a memory storage 18, and display panel 20. The display panel 20 includes an array of pixels 22 arranged in rows and columns. Each of the pixels 22 is individually programmable to emit light with individually programmable luminance values. The controller 16 receives digital data indicative of information to be displayed on the display panel 20. The controller 16 sends signals 32 to the source driver 14 and scheduling signals 34 to the gate driver 12 to drive the pixels 22 in the display panel 20 to display the information indicated. The plurality of pixels 22 associated with the display panel 20 thus

comprise a display array (“display screen”) adapted to dynamically display information according to the input digital data received by the controller 16. The display screen can display, for example, video information from a stream of video data received by the controller 16. The supply voltage 24 can provide a constant power voltage or can be an adjustable voltage supply that is controlled by signals from the controller 116. The display system 10 can also incorporate features from a current source or sink (not shown) to provide biasing currents to the pixels 22 in the display panel 20 to thereby decrease programming time for the pixels 22.

[0021] For illustrative purposes, the display system 10 in FIG. 1 is illustrated with only four pixels 22 in the display panel 20. It is understood that the display system 10 can be implemented with a display screen that includes an array of similar pixels, such as the pixels 22, and that the display screen is not limited to a particular number of rows and columns of pixels. For example, the display system 10 can be implemented with a display screen with a number of rows and columns of pixels commonly available in displays for mobile devices, monitor-based devices, and/or projection-devices.

[0022] The pixel 22 is operated by a driving circuit (“pixel circuit”) that generally includes a driving transistor and a light emitting device. Hereinafter the pixel 22 may refer to the pixel circuit. The light emitting device can optionally be an organic light emitting diode, but implementations of the present disclosure apply to pixel circuits having other electroluminescence devices, including current-driven light emitting devices. The driving transistor in the pixel 22 can optionally be an n-type or p-type amorphous silicon thin-film transistor, but implementations of the present disclosure are not limited to pixel circuits having a particular polarity of transistor or only to pixel circuits having thin-film transistors. The pixel circuit 22 can also include a storage capacitor for storing programming information and allowing the pixel circuit 22 to drive the light emitting device after being addressed. Thus, the display panel 20 can be an active matrix display array.

[0023] As illustrated in FIG. 1, the pixel 22 illustrated as the top-left pixel in the display panel 20 is coupled to a power enable (PE) signal line 40, measurement (MEAS) signal line 42, a supply line 26i, a data line 23j, and an enable measurement (EM) signal line 44i. The supply line 26i may be charged with VDD.

[0024] The top-left pixel 22 in the display panel 20 can correspond a pixel in the display panel in a “ith” row and “jth” column of the display panel 20. Similarly, the top-right pixel 22 in the display panel 20 represents a “jth” row and “mth” column; the bottom-left pixel 22 represents an “nth” row and “jth” column; and the bottom-right pixel 22 represents an “nth” row and “mth” column. Each of the pixels 22 is coupled to the PE signal line 40, MEAS signal line 42; along with the appropriate supply lines (e.g., the supply lines 26i and 26n), data lines (e.g., the data lines 23j and 23m), and EM signal lines (e.g., the EM signal lines 44i and 44n). It is noted that aspects of the present disclosure apply to pixels having additional connections, such as connections to a select line.

[0025] With reference to the top-left pixel 22 shown in the display panel 20, PE signal line 40 and MEAS signal line 42 are provided by the gate driver 12, and can be utilized to enable, for example, a programming operation of the pixel 22 by activating a switch or transistor to allow the data line

23j to program the pixel 22. The data line 23j conveys programming information from the source driver 14 to the pixel 22. For example, the data line 23j can be utilized to apply a programming voltage or a programming current to the pixel 22 in order to program the pixel 22 to emit a desired amount of luminance. The programming voltage (or programming current) supplied by the source driver 14 via the data line 23j is a voltage (or current) appropriate to cause the pixel 22 to emit light with a desired amount of luminance according to the digital data received by the controller 16. The programming voltage (or programming current) can be applied to the pixel 22 during a programming operation of the pixel 22 so as to charge a storage device within the pixel 22, such as a storage capacitor, thereby enabling the pixel 22 to emit light with the desired amount of luminance during an emission operation following the programming operation. For example, the storage device in the pixel 22 can be charged during a programming operation to apply a voltage to one or more of a gate or a source terminal of the driving transistor during the emission operation, thereby causing the driving transistor to convey the driving current through the light emitting device according to the voltage stored on the storage device.

[0026] Generally, in the pixel 22, the driving current that is conveyed through the light emitting device by the driving transistor during the emission operation of the pixel 22 is a current that is supplied by the supply line 26i. The supply line 26i can provide a positive supply voltage (e.g., the voltage commonly referred to in circuit design as “VDD”).

[0027] The display system 10 also includes a readout circuit 15 which is integrated with the source driver 14. With reference again to the top left pixel 22 in the display panel 20, the data line 23j connects the pixel 22 to the readout circuit 15. The data line 23j allows the readout circuit 15 to measure a current associated with the pixel 22 and hereby extract information indicative of a degradation of the pixel 22. Readout circuit 15 converts the associated current to a corresponding voltage. This voltage is converted into a 10 to 16 bit digital code and is sent to the digital control 16 for further processing or compensation.

[0028] FIG. 2 is a circuit diagram of a simple individual driver circuit 50 which contains a pixel 22, a source driver 14 and three switches controlling by MEAS 66, EM 68 and PE 64 signal. The pixel 22 in FIG. 2 include a drive transistor T1 coupled to an organic light emitting device D1 and a storage capacitor C_S for storing programming information and allowing the pixel circuit 22 to drive the light emitting device after being addressed. In FIG. 2, circuit 50 is in programming mode.

[0029] As explained above, each pixel 22 in the display panel 20 in FIG. 1 is driven by the method shown in the driver circuit 50 in FIG. 2. The driver circuit 50 includes a drive transistor T1 coupled to an organic light emitting device D1, a storage capacitor C_S for storing programming information and a source driver 14 and three switches controlling by MEAS 66, EM 68 and PE 64 signal. In this example, the organic light emitting device D1 is a luminous organic material which is activated by current flow and whose brightness is a function of the magnitude of the current. A supply voltage input 54 is coupled to the drain of the drive transistor T1. The supply voltage input 54 in conjunction with the drive transistor T1 supplies current to the light emitting device D1. The current level may be controlled via the source driver 14 in FIG. 1. In one example,

the drive transistor T1 is a thin film transistor fabricated from hydrogenated amorphous silicon. In another example, low-temperature polycrystalline-silicon thin-film transistor (“LTPS-TFT”) technology can also be used. Other circuit components such as capacitors and transistors (not shown) may be added to the simple driver circuit 50 to allow the pixel to operate with various enable, select and control signals such as those input by the gate driver 12 in FIG. 1. Such components are used for faster programming of the pixels, holding the programming of the pixel during different frames and other functions.

[0030] When the pixel 22 is required to have a defined brightness in applications, the gate of the drive transistor T1 is charged to a voltage where the transistor T1 generates a corresponding current to flow through the organic light emitting device (OLED) D1, creating the required brightness. The voltage at the gate of the transistor T1 can be either created by direct charging of the node with a voltage or self-adjusted with an external current.

[0031] During the programming mode, rows of pixels 22 are selected on a row by row basis. For example, the “ith” row of pixels 22 are selected and enabled by the gate driver 12, in which the EM signal line 44i is set to zero, i.e. EM=0. All pixels 22 in the “ith” row are connected to the source driver 14, such that the MEAS signal line 42 is set to zero, i.e. MEAS=0, and the PE signal line 40 is set to equal VDD, i.e. PE=VDD, for the “ith” row. The data is converted to data current, referred to as I_DATA 56 and flows into pixel. This data current 56 generates a Vgs voltage in T1 transistor which is stored in C_S capacitor. When the pixel is in operational mode and is connected VDD, the voltage stored in C_S capacitor generated a current in T1 transistor which is equal to I_DATA 56.

[0032] FIG. 3 is the circuit diagram of the simple individual driver circuit 50 as illustrated in FIG. 2 when in measurement mode. During the measurement mode, each row of pixels 22 are selected on a row by row basis, and enabled by the gate driver 11, i.e. EM=0, and all pixels 22 are connected to the source driver 14, i.e. MEAS=0 and PE=VDD, as described in FIG. 2. The pixel current, I_{Pixel}, 70 flows into source driver 14 and is measured by a Readout Circuit (ROC) 15. The ROC 15 measures the pixel current 70 and converts it to a correspondence voltage. This voltage is converted to 10 to 16 bit digital code and is sent to digital processor to be used for further processing or compensation.

[0033] FIG. 4 is the circuit diagram of the simple individual driver circuit 50 as illustrated in FIG. 2 when in normal operation mode. Normal operation mode may occur after the programming of all the rows. During normal operation mode, all pixels 22 are connected to their specific supply line, e.g. the “ith” row is connected to supply line 26i, while all pixels are disconnected from source driver 14, such that the MEAS signal line 42 is set to VDD, i.e. MEAS=VDD, and the PE signal line 40 is set to equal zero, i.e. PE=0, for the “ith” row. Pixel current, I_{Pixel}, 70 which is equal to the data current, I_{Data}, 56 flows into pixel 22 and OLED D1 has a luminance correspondence to the Pixel current 70.

[0034] FIG. 5 is the circuit diagram of the simple individual driver circuit 50 as illustrated in FIG. 2 when in programming mode but when the programming is directed toward another row. During the programming mode, the programming is performed on a row by row basis. The results in only one row of pixels 22, i.e. the “ith” row, being

connected to source driver 14 while the remaining rows of pixels 22, i.e. the “jth” row, are off with no pixel current 70. During this time, the EM signal line 44j is set to VDD, i.e. EM=VDD, while the MEAS signal line 42 is set to zero, i.e. MEAS=0, and the PE signal line 40 is set to equal VDD, i.e. PE=VDD, for the “ith” row. During this time, there will be only a leakage current flowing into the OLED D1 and pixel 22 as shown in FIG. 5.

[0035] FIG. 6 is a diagram of an exemplary display system 100. The display system 100 includes a gate driver 112, a source driver 114, a digital controller 116, a memory storage 118, and display panel 120 and two TFT transistors 119 working as switches for each column. The display panel 120 includes an array of pixels 122 arranged in rows and columns. Each of the pixels 122 is individually programmable to emit light with individually programmable luminance values. The controller 116 receives digital data indicative of information to be displayed on the display panel 120. The controller 116 sends signals 132 to the source driver 114 and scheduling signals 134 to the gate driver 112 to drive the pixels 122 in the display panel 120 to display the information indicated. The plurality of pixels 122 associated with the display panel 120 thus comprise a display array (“display screen”) adapted to dynamically display information according to the input digital data received by the controller 116. The display screen can display, for example, video information from a stream of video data received by the controller 116. The supply voltage 124 can provide a constant power voltage or can be an adjustable voltage supply that is controlled by signals from the controller 116.

[0036] For illustrative purposes, the display system 100 in FIG. 6 is illustrated with only four pixels 122 in the display panel 120. It is understood that the display system 100 can be implemented with a display screen that includes an array of similar pixels, such as the pixels 122, and that the display screen is not limited to a particular number of rows and columns of pixels. For example, the display system 100 can be implemented with a display screen with a number of rows and columns of pixels commonly available in displays for mobile devices, monitor-based devices, and/or projection-devices.

[0037] The pixel 122 is operated by a driving circuit (“pixel circuit”) that generally includes a driving transistor and a light emitting device. Hereinafter the pixel 122 may refer to the pixel circuit. The light emitting device can optionally be an organic light emitting diode (OLED), but implementations of the present disclosure apply to pixel circuits having other electroluminescence devices, including current-driven light emitting devices. The driving transistor in the pixel 122 can optionally be an n-type or p-type amorphous silicon thin-film transistor, but implementations of the present disclosure are not limited to pixel circuits having a particular polarity of transistor or only to pixel circuits having thin-film transistors. The pixel circuit 122 can also include a storage capacitor for storing programming information and allowing the pixel circuit 122 to drive the light emitting device after being addressed. Thus, the display panel 120 can be an active matrix display array.

[0038] As illustrated in FIG. 6, the pixel 122 illustrated as the top-left pixel in the display panel 120 is coupled to a power enable (PE) signal line 140, measurement (MEAS) signal line 142, a supply line 126j, a data line 123j, and a write (WR) signal line 144i. The supply line 126j may be charged with VDD.

[0039] The top-left pixel 122 in the display panel 120 can correspond a pixel in the display panel in an “ith” row and “jth” column of the display panel 120. Similarly, the top-right pixel 122 in the display panel 120 represents an “ith” row and “mth” column; the bottom-left pixel 122 represents an “nth” row and “jth” column; and the bottom-right pixel 122 represents an “nth” row and “mth” column. Each of the pixels columns is connected to two TFTs 119. One TFT 119 is coupled between the data line (123j and 123m) and pixel supply voltage line (1211 and 121m) and is controlled by the PE signal line 140. The second TFT is coupled between pixel supply voltage line (121j and 121m) and supply voltage line (126j and 126m) and is controlled by the MEAS signal line 142; The display panel 120 is also coupled with the appropriate supply lines (e.g., the supply lines 126j and 126m), data lines (e.g., the data lines 123j and 123m), and write WR signal lines (e.g., the WR signal lines 144i and 144n). It is noted that aspects of the present disclosure apply to pixels having additional connections, such as connections to a select line or monitor line.

[0040] With reference to the top-left pixel 122 shown in the display panel 120, PE signal line 140, MEAS signal line 42 and W1R (144i and 144n) write signal are provided by the gate driver 112 and can be utilized to enable, for example, a programming operation of the pixel 122 by activating TFT transistors 119 and other switches or transistors in pixel 122 to allow the data line 1231 to program the pixel 122. The data line 1231 conveys programming information from the source driver 114 to the pixel 122. For example, the data line 123j can be utilized to apply a programming voltage or a programming current to the pixel 122 in order to program the pixel 122 to emit a desired amount of luminance. The programming voltage (or programming current) supplied by the source driver 114 via the data line 123j is a voltage (or current) appropriate to cause the pixel 122 to emit light with a desired amount of luminance according to the digital data received by the controller 116. The programming voltage (or programming current) can be applied to the pixel 122 during a programming operation of the pixel 122 so as to charge a storage device within the pixel 122, such as a storage capacitor, thereby enabling the pixel 122 to emit light with the desired amount of luminance during an emission operation following the programming operation. For example, the storage device in the pixel 122 can be charged during a programming operation to apply a voltage to one or more of a gate or a source terminal of the driving transistor during the emission operation, thereby causing the driving transistor to convey the driving current through the light emitting device according to the voltage stored on the storage device.

[0041] Generally, in the pixel 122, the driving current that is conveyed through the light emitting device by the driving transistor during the emission operation of the pixel 122 is a current that is supplied by the supply line 126j. The supply line 126j can provide a positive supply voltage (e.g., the voltage commonly referred to in circuit design as “VDD”).

[0042] The display system 100 also includes a readout circuit 115 which is integrated with the source driver 114. With reference again to the top left pixel 122 in the display panel 120, the data line 123j connects the pixel 122 to the readout circuit 115. The data line 123j allows the readout circuit 115 to measure a current associated with the pixel 122 and hereby extract information indicative of a degradation of the pixel 122. Readout circuit 115 converts the associated

current to a corresponding voltage. This voltage is converted into a 10 to 16 bit digital code and is sent to the digital control 116 for further processing or compensation.

[0043] FIG. 7 is a circuit diagram of a simple individual driver circuit 200 which contains a pixel 122 which is connected to supply voltage VDD 154, a data voltage VDATA 156 and is controlled by the write WR signal 158. The pixel 122 in FIG. 2 includes a switch transistor T2, a drive transistor T1 coupled to an organic light emitting device (OLED) D1, the switch transistor T2 and a storage capacitor C_S for storing programming information and allowing the pixel circuit 122 to drive the light emitting device after being addressed. In FIG. 7, when the write WR signal 158 goes low, it enables the transistor T2 and the VDATA 156 is stored on the capacitor C_S . The V_{gs} (gate to source) voltage of the drive transistor T1 which is stored on the capacitor C_S is equal to:

$$V_{gs}=VDATA-VDD$$

[0044] As explained above, each pixel 122 in the display panel 120 in FIG. 6 is driven by the method shown in the driver circuit 200 in FIG. 7. The driver circuit 200 includes a switch transistor T2, a drive transistor T1 coupled to an organic light emitting device (OLED) D1, a storage capacitor C_S for storing programming information. VDATA 156 voltage comes from the source driver 114 and is stored on the capacitor C_S . The switch transistor T2 is controlled by WR 58 signal.

[0045] In this example, the organic light emitting device (OLED) D1 is a luminous organic material which is activated by current flow and whose brightness is a function of the magnitude of the current. A supply voltage input 154 is coupled to the source (or drain) of the drive transistor T1. The supply voltage input 154 in conjunction with the drive transistor T1 supplies current to the light emitting device D1. The current level may be controlled via the source driver 114 in FIG. 6 and can be determined by the following formula:

$$I_{Pixel}=\frac{1}{2}k(VDATA-VDD-V_{th})^2$$

[0046] Where k depends on the size of the drive transistor T1 and V_{th} is the threshold voltage of the drive transistor T1. In one example, the drive transistor T1 is a thin film transistor fabricated from hydrogenated amorphous silicon. In another example, low-temperature polycrystalline-silicon thin-film transistor (“LTPS-TFT”) technology can also be used. Other circuit components such as capacitors and transistors (not shown) may be added to the simple driver circuit 200 to allow the pixel to operate with various enable, select and control signals such as those input by the gate driver 112 in FIG. 6. Such components are used for faster programming of the pixels, holding the programming of the pixel during different frames and other functions.

[0047] When the pixel 122 is required to have a defined brightness in applications, the gate of the drive transistor T1 is charged to a voltage where the transistor T1 generates a corresponding current to flow through the organic light emitting device (OLED) D1, creating the required brightness. The voltage at the gate of the transistor T1 can be either created by direct charging of the node with a voltage or self-adjusted with an external current.

[0048] During the programming mode, rows of pixels 122 are selected on a row by row basis. For example, the “ith” row of pixels 122 are selected and enabled by the gate driver 112, in which the WR signal line 144i is set to zero, i.e. WR=0. All pixels 122 in the “ith” row are connected to the

source driver **114**, such that the MEAS signal line **142** is set to VDD, i.e. MEAS=VDD, and the PE signal line **140** is set to equal 0, i.e. PE=0, for the “ith” row. The data VDATA (**123j** and **123m**) as a voltage (or can be a current) is stored on the capacitors C_S inside pixels **122**. This data generates a V_{gs} voltage in T1 transistor which is stored in C_S capacitor. When the pixel is in operational mode and is connected VDD, the voltage stored in C_S capacitor generated a current in T1 transistor which is equal to:

$$I_{Pixel} = \frac{1}{2} k (V_{DATA} - V_{DD} - V_{th})^2$$

Pixel current, I_{Pixel} , flows into pixel **122** and OLED D1 has a luminance correspondence to the Pixel current.

[0049] FIG. **8** is a block diagram of an embodiment of a column of pixel circuit (“jth” column) **300** in programming modes. During the this mode, each row of the circuit **300** are selected on a row by row basis and enabled by the gate driver **112** in which the WR signal line **144i** is set to zero, i.e. WR=0, and all pixels **122** are connected to the source driver **114** and the supply voltage VDD. The MEAS signal line **142** is set to VDD, i.e. MEAS=VDD, and the PE signal line **140** is set to equal 0, i.e. PE=0, as described in FIG. **8**. In the first write mode **301**, the write signal WR[1] is set to zero, i.e. WR[1]=0, and the row **1** is connected to the source driver **114** and the data VDATA[j] **123j** is stored in capacitor C_S in pixel in the row **1** and the “jth” column. In the second write mode **302**, the write signal WR[2] is set to zero, i.e. WR[2]=0, and the row **2** is connected to the source driver **114** and the data VDATA[j] **123j** is stored in capacitor C_S in pixel in the row **2** and the “jth” column. In the third write mode **303**, the write signal WR[i] (i=3 to n-1) is set to zero one by one, i.e. WR[i]=0 (i=3 to n-1), and the row i (i=3 to n-1) is connected to the source driver **114** one by one and the data VDATA[j] **123j** is stored in capacitor C_S in pixel in the “ith” row and the “jth” column. In the fourth write mode **304**, the write signal WR[n] is set to zero, i.e. WR[n]=0, and the row n is connected to the source driver **114** and the data VDATA[j] **123j** is stored in capacitor C_S in pixel in the row n and the “jth” column.

[0050] In order to measure the pixel current, in the first step, all data line VDATA (**123j** and **123m**) are set to have the same voltage as supply voltage (VDD) and all write signal WR (**144i** and **144n**) are set to zero, i.e. WR[i]=0 (i=1 to n), then all capacitors’ voltages inside pixel **122** will be zero and OLED devices D1 show black color. In the second step, the leakage current is measured. In the third step, the data is programmed on the row i. Finally, the row i is selected and the pixel current is measured.

[0051] FIG. **9** is a block diagram of an embodiment of a column of pixel circuit (“jth” column) **400** in programming mode. In first step, data line VDATA **123j** has the same voltage as supply voltage VDD **126j**. All write signals WR (**144i**, **144n**) are set to zero, i.e. WR=0, and the MEAS signal line **142** is set to VDD, i.e. MEAS=VDD, and the PE signal line **140** is set to equal 0, i.e. PE=0, as described in FIG. **9**. All pixels **122** in the circuit **400** are in write mode **401**. All capacitors’ voltages are set to zero and OLED devices D1 show black color. Alternatively all of the pixels can be driven to black one at a time sequentially similar to how the video is driven onto the panel.

[0052] FIG. **10** is a block diagram of an embodiment of a column of pixel circuit (“jth” column) **500** in measurement mode. In the second step, the leakage current is measured immediately after setting the capacitors’ voltages of all

pixels in the circuit **500** to zero. The WR signal line (**144i** and **144n**) is set to VDD, i.e. WR=VDD, and the MEAS signal line **142** is set to 0, i.e. MEAS=0, and the PE signal line **140** is set to equal VDD, i.e. PE=VDD, as described in FIG. **10**. The circuit **500** is disconnected from the supply voltage and connected to the data line, VDATA **123j**. The leakage current of the pixels **122** in “jth” column (the circuit **500**), $I_{Leakage}$ **190** flows into the source driver **114** and is measured by a Readout Circuit (ROC) **115**. The ROC **115** measures the leakage current ($I_{Leakage}$) **190** and converts it to a correspondence voltage. This voltage is converted to 10 to 16 bit digital code and is sent to digital processor to be used for further processing or compensation.

[0053] The third step is to write a data into the pixel which is of interested to measure its current. FIG. **11** is a block diagram of an embodiment of a column of pixel circuit (“jth” column) **600** in programming mode. In this mode the “ith” row is programmed. The WR signal line **144i** is set to zero, i.e. WR[i]=0, and other WR signal lines **144n** are set to equal VDD, i.e. WR[n]=VDD, and the MEAS signal line **142** is set to equal VDD, i.e. MEAS=VDD, and the PE signal line **140** is set to zero, i.e. PE=0, as described in FIG. **11**. The pixel **122** in “ith” row is programmed to VDATA **123j** and a current corresponded to it flows into the pixel. No current except for the leakage current flow into other pixel **122** in “jth” column.

[0054] The last step is to measure the pixel current of the “ith” row. FIG. **12** is a block diagram of an embodiment of a column of pixel circuit (“jth” column) **700** in measurement mode. The pixel current of the “ith” row plus the leakage current of the other pixels are measured in this mode. The WR signal line (**144i** and **144n**) is set to VDD, i.e. WR=VDD, and the MEAS signal line **142** is set to 0, i.e. MEAS=0, and the PE signal line **140** is set to equal VDD, i.e. PE=VDD, as described in FIG. **12**. The circuit **700** is disconnected from the supply voltage and connected to the data line, VDATA **123j**. The pixel current of the “ith” row plus the leakage current of other pixels in “jth” column (the circuit **700**), $I_{Pixel} + I_{Leakage}$ **192** flows into the source driver **114** and is measured by a ROC **115**. The ROC **115** measures the current **192** and converts it to a correspondence voltage.

[0055] This voltage is converted to 10 to 16 bit digital code. The difference between the current measured in the last step and the leakage current in the step two, is the pixel current of the “ith” row pixel in “jth” column circuit **700** according to the following formula:

$$I_{Pixel} = (\text{current measured in step 4}) - (\text{current measured in step 2})$$

$$I_{Pixel} = (I_{Pixel} + I_{Leakage}) - I_{Leakage}$$

[0056] In order to measure the OLED current, all four steps described to measure the pixel current are repeated here. In the step one as shown in FIG. **9**, the data line is set to equal VDD and the capacitors’ voltages inside pixels are set to zero. In the step two as shown in FIG. **10**, the leakage current, $I_{Leakage}$ **190** of the pixels is measured. In the step three as shown in FIG. **11**, the “ith” row is selected and the data line VDATA **123j** is derived with lowest voltage. It causes the T1 transistor inside the “ith” pixel **122** is pushed to the triode region and behaves like a switch. In the step four as shown in FIG. **8**, the OLED D1 of the “ith” pixel **122** is connected to virtual ground **806** of an integrator **810** through the T1 transistor inside the “ith” pixel **122** and the transistor **119** connected between the pixel supply voltage

node **121j** and the data line **123j** and the switch **807** inside the ROC **115**. By ignoring the voltage drop on the switches, the OLED D1 of the “ith” pixel **122** will have the same voltage as the bias voltage V_B **805**. The OLED current of the “ith” row pixel plus the leakage current of other pixels in “jth” column (the circuit **800**), $I_{Oled}+I_{Leakage}$, **194** flows into the source driver **114** and is measured by a ROC **115**. The ROC **115** measures the current **194** and converts it to a correspondence voltage. This voltage is converted to 10 to 16 bit digital code **802**. The difference between the current measured in the step four and the leakage current in the step two, is the OLED current of the “ith” row pixel in “jth” column circuit **800** according to the following formula:

$$I_{Oled} = (\text{current measured in step 4}) - (\text{current measured in step 2})$$

$$I_{Oled} = (I_{Oled} + I_{Leakage}) - (I_{Leakage})$$

[0057] The ROC **115** as shown in FIG. **13** includes one switch **807**, an integrator **810** and an analog to digital converter (ADC) **801**. The integrator includes a reset switch **808**, an integrating capacitor C_I and a bias voltage V_B **805**. The integrator integrates the current coming from pixel **122** and converts it to a corresponding voltage. The voltage is converted to 10 to 16 bit digital code **802** by the ADC **801**.

[0058] While particular embodiments and applications of the present invention have been illustrated and described, it is to be understood that the invention is not limited to the precise construction and compositions disclosed herein and that various modifications, changes, and variations can be apparent from the foregoing descriptions without departing from the spirit and scope of the invention as defined in the appended claims.

1. A method of determining the current of a first pixel circuit in a display system, the display system including a plurality of pixel circuits arranged in rows and columns, a source driver, a supply voltage, and an address driver, the first pixel circuit of the plurality of pixel circuits coupled to the source driver over a data line and via a first switch and a second switch coupled together in series, the first pixel circuit coupled to the supply voltage over a supply line via the first switch and a third switch coupled together in series, the third switch coupled to a node between the first switch and the second switch, and a gate of each of the first, second, and third switches respectively coupled to the address driver, said method comprising

providing programming signals to the first pixel circuit from the source via the data line and the first and second switches,

measuring over the data line and the first and second switches, current flowing through the first pixel circuit according to the programming of the first pixel circuit, and

extracting a voltage value from the current measurement.

2. The method of claim 1, wherein the pixel circuit comprises a light-emitting device, and a drive transistor, the method further comprising:

supplying current to the light-emitting device through the drive transistor.

3. The method of claim 2, wherein the light-emitting device of the first pixel circuit comprises an organic light emitting diode.

4. (canceled)

5. A method of determining the current of a light-emitting device in a first pixel circuit in a display system, the display

system including a plurality of pixel circuits arranged in rows and columns, a source driver, a supply voltage, and an address driver, the first pixel circuit of the plurality of pixel circuits coupled to the source driver over a data line and via a first switch and a second switch coupled together in series, the first pixel circuit coupled to the supply voltage over a supply line and via the first switch and a third switch coupled together in series, the third switch coupled to a node between the first switch and the second switch, and a gate of each of the first, second, and third switches coupled respectively to the address driver, the first pixel circuit connected to a virtual ground of an integrator inside a readout circuit by the data line, said method comprising

providing programming signals to the first pixel circuit from the source via the data line and the first and second switches,

measuring over the data line and the first and second switches, current flowing through a light-emitting device of the first pixel circuit, and

extracting a voltage value from the current measurement.

6. The method of claim 1, wherein the source driver comprises a readout circuit, and wherein the readout circuit perform said measuring.

7. The method of claim 6, wherein the method further comprises:

converting the measured current into a digital code; and sending a digital code to a digital processor for processing, wherein said extracting the voltage value from the current measurement comprises converting the measured current into the digital code.

8. The method of claim 7, wherein the method further comprises:

converting the measured current into a 10 to 16 bit digital code.

9. A display system comprising:

a plurality of pixel circuits arranged in rows and columns;

a source driver;

a supply voltage;

an address driver;

a first pixel circuit of the plurality of pixel circuits coupled to the source driver over a data line and via a first switch and a second switch coupled together in series, the first pixel circuit coupled to the supply voltage over a supply line and via the first switch and a third switch coupled together in series, the third switch coupled to a node between the first and second switch, and a gate of each of the first, second, and third switches respectively coupled to the address driver; and

a controller coupled to the source driver, the address driver, and the supply voltage, the controller adapted to control the plurality of pixels and the first, second, and third switch.

10. The display system of claim 9 wherein the controller is further adapted to:

provide programming signals to the first pixel circuit from the source via the data line and the first and second switches,

measure over the data line and the first and second switches, current flowing through the first pixel according to the programming of the first pixel, and

extract a voltage value from the current measurement.

11. The display system of claim 10, wherein each pixel circuit comprises a light-emitting device and a drive transistor, and wherein the controller is further adapted to:

supply current to the light-emitting device through the drive transistor.

12. The display system of claim **11**, wherein the light-emitting device of the first pixel circuit comprises an organic light emitting diode

13. The display system of claim **9** wherein the controller is further adapted to:

provide programming signals to the first pixel circuit from the source via the data line and the first and second switches,

measure over the data line and the first and second switches, current flowing through a light-emitting device of the first pixel circuit, and

extract a voltage value from the current measurement.

14. The display system of claim **9**, wherein the source driver comprises a readout circuit, and wherein the controller is further adapted to control the readout circuit to perform said measurement of current flowing through the light-emitting device of the first pixel circuit.

15. The display system of claim **14**, wherein the controller is further adapted to:

send a digital code to a digital processor for processing, wherein said extraction of the voltage value from the current measurement comprises converting the measured current into the digital code.

16. The display system of claim **15**, wherein the controller is further adapted to convert the measured current into a 10 to 16 bit digital code.

* * * * *

专利名称(译)	通过数据线进行像素测量		
公开(公告)号	US20190251909A1	公开(公告)日	2019-08-15
申请号	US16/028073	申请日	2018-07-05
[标]申请(专利权)人(译)	伊格尼斯创新公司		
申请(专利权)人(译)	IGNIS创新INC.		
当前申请(专利权)人(译)	IGNIS创新INC.		
[标]发明人	TALEBZADEH JAFAR LEERENTVELD RAY		
发明人	TALEBZADEH, JAFAR LEERENTVELD, RAY		
IPC分类号	G09G3/3283 G09G3/00 G09G3/325 H05B33/08		
CPC分类号	G09G3/3283 G09G3/006 G09G3/325 H05B33/0896 G09G3/3225 G09G3/3233 G09G2320/029 H05B45/60		
优先权	62/629450 2018-02-12 US		
外部链接	Espacenet USPTO		

摘要(译)

一种用于确定像素电路和有机发光二极管 (OLED) 的电流的系统和方法。像素电路通过数据线连接到源极驱动器。由源极驱动器提供给像素电路的电压 (或电流)。可以通过读出电路测量像素和OLED的电流。可以提取来自测量电流的电压值并将其提供给处理器以进行进一步处理。

